

**LIQUID NITROGEN PROVIDES EFFECTIVE REMOVAL OF
FOULING IN PETROLEUM REFINERY PROCESS EQUIPMENT**

B. Foley-Saxon
Conco Services Corporation
Verona, Pennsylvania, U.S.A.

T. Meyers
Conco Services Corporation
Deer Park, Texas, U.S.A.

ABSTRACT

Pressurized liquid nitrogen (LN₂) can be used as a highly effective means for completely and rapidly removing the most tenacious fouling deposits encountered in petroleum refinery process equipment. As a result, significant improvements can be seen in process flow rates and in process energy and pollution management. In addition, the use of a water-free based cleaning method ensures that there will not be any reactions with the deposit and there will be minimal waste streams or pollution that the plant will be responsible for disposing of. This paper will provide a detailed description of how liquid nitrogen cleaning works, with particular focus on the NitroLance™ cleaning system that uses a controlled stream of ultra high-pressure LN₂ at pressures up to 55,000 psi and temperatures as low as -250°F to fracture just about any deposit. In addition, data will be provided to confirm that base metals are unchanged and unharmed by the brief contact of metal with LN₂ during a cleaning.

1. INTRODUCTION

Since nitrogen was first liquefied in a laboratory in the late 19th century, science and industry have found myriad uses for liquid nitrogen (LN₂), from dermatology to cryogenics to culinary arts. NASA has even used LN₂ to clean the surface of the space shuttle and other aircraft, and decades ago, the U.S. Department of Energy developed the use of LN₂ to cut into metal storage tanks holding radioactive material. LN₂ was an ideal cleaning agent for this job. It wouldn't spark and be a fire accelerant, allaying concerns over the potentially combustible contents of the storage tanks, and LN₂ evaporates into the atmosphere after use, leaving behind powder-like residue that can be swept or vacuumed. This gas has a broad reach and has come a long way.

Petroleum refinery process units have traditionally been cleaned with conventional methods like high-pressure water blasting, hydrodrilling, chemical cleaning and mechanical scrapers or brushes. With the exception of mechanical scrapers or brushes, all of these approaches carry burdens for the plant. Conventional cleaning methods like high pressure water blasting can use large volumes of water that becomes polluted during the cleaning process. Post-cleaning wastewater disposal can require additional unit downtime and personnel, which incurs additional expense for the plant. In addition to wastewater, the fouling deposition removed during cleaning can amount to tons of potentially volatile waste matter that must be disposed of responsibly.

In our corner of industry, LN₂ has proven to be highly effective at removing the fouling that so many unit components are prone to at petroleum refinery plants. Petroleum refinery process equipment, such as heat exchangers in; sulfur recovery units, waste heat boilers, sulfur condensers and thermal reactor boilers, are prone to fouling. And fouling scenarios are sometimes severe. Unit tubes can become completely obstructed with tenacious deposits like iron pyrite, calcium carbonate and hard varnish, rendering the unit unavailable for use. Interruptions and declines in unit function like this can be extremely costly for a plant, and it is not uncommon for plant engineers to consider equipment replacement altogether; a six or seven figure purchase. Often, despite efforts to mitigate fouling with conventional cleaning methods, many plants still have compromised units. This is when a next-level cleaning strategy like LN₂ is vital; it can be the difference between returning your unit to good working order or buying a new unit.

2. THE MECHANICS OF LIQUID NITROGEN CLEANING

The NitroLance™ high-pressure liquid nitrogen cleaning system is the prevailing LN₂ cleaning system available for industrial applications today. The complete self-contained system arrives on site in the NitroLance truck. Doors open to reveal the entire system mounted on a moveable platform that is situated in close proximity to the unit being cleaned. The system hose and nozzle extends to more than 300 feet from the platform. The NitroLance technician clad in head to toe protective gear delivers a controlled stream of LN₂ at variable pressures, angles and temperatures to the surface of the fouling deposition. The technician will adjust the values of the LN₂ flow to penetrate and break

up the deposit at hand. The NitroLance cleaning system can clean internal surfaces and external tube surfaces like those found in economizers, sulfur recovery units and others, as well as vertical or horizontal heat exchangers in place, eliminating the need for costly crane removal services.

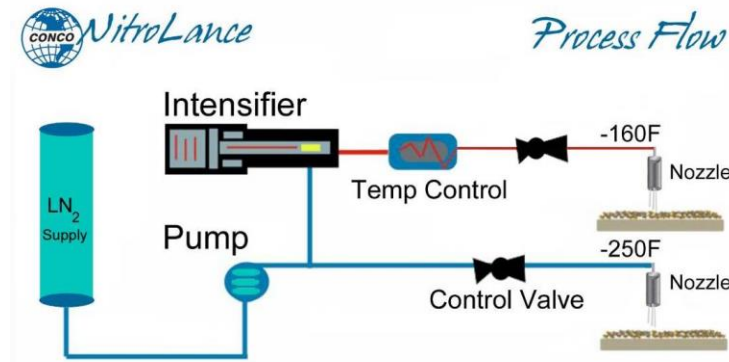

Figure 1. NitroLance Process Flow

2.1 MECHANISMS OF ACTION

The NitroLance super-cooled cryogenic jet emerges from the nozzle entering the solid deposit cracks and crevices and then expands, rapidly breaking up deposits through three mechanisms of action: mechanical pressure, super cooling and volumetric expansion.

2.1.1 MECHANICAL PRESSURE

The mechanical pressure exerted at the nozzle tip of the NitroLance will depend on the characteristics of the fouling that is to be removed. NitroLance nozzle pressures will vary from 5,000 to 55,000 psi, and will be adjusted by the technician. A fouling profile is conducted in the lead up to a NitroLance cleaning so that plant personnel and the Conco technician will have a good understanding of the deposit characteristics. This provides a baseline for how to proceed with LN₂ pressure, angle and temperature to break up the deposit quickly and safely.

2.1.2 SUPER COOLING

The super-cooled LN₂ in the NitroLance ranges from -160°F to -250°F at the nozzle and is the fundamental catalyst for the fracturing of deposition and obstructions. The precise temperature will quickly and safely break apart any fouling, leaving the metal surface unharmed and unchanged, and rendering the hard, tenacious fouling a powder-like substance.

2.1.3 VOLUMETRIC EXPANSION

As the high-density super-cooled LN₂ penetrates the cracks and crevices of the surface of the deposition, the LN₂ rapidly vaporizes into a gas, expanding by nearly 700 times. The

rapid expansion of the gas combined with the mechanical pressure and super-cooled temperature causes the deposit material to break apart and detach from the metal it is bonded to. Once fractured, the deposition waste is like powder and can be vacuumed or swept away. Because LN₂ is a gas, it evaporates into the atmosphere after cleaning as a harmless byproduct.

Industrial applications of the NitroLance cleaning system have removed incredibly difficult deposits safely and without producing secondary waste streams. The technology has been used to restore flow to tubes completely blocked with hardened calcium carbonate, and has done so far more quickly than high-pressure water or chemical cleaning.

3. LN₂ IN ACTION

In July of 2017, the NitroLance was used at an industrial plant on the U.S. east coast that manufactures para-aramid synthetic fibers. One hundred percent of the plant heat exchanger's niobium tubes were blocked, end-to-end, with a lava rock-like deposit. Before deciding to proceed with the NitroLance cleaning, the plant was considering a \$750,000 replacement heat exchanger. The decision to clean the exchanger meant that the plant could save the valuable component, but they proceeded with caution. They were wisely focused on safety and maintaining the integrity of the heat exchanger's valuable niobium tubes. Tube damage was not an option, and so high-pressure water and drilling were prohibited from any proposed cleaning strategy.

3.1 HANDS FREE LN₂ CLEANING SYSTEM

For this application, the plant and Conco opted for the NitroLance hands free operating system. The upgraded NitroLance system consists of an X-Y indexer that is controlled with pneumatic motors that drive the mounted Z-axis rail left, right, up or down. The controls for the system can be performed by one technician from a control stand and at a safe distance from plant equipment and operations.



Figure 2. NitroLance can be equipped for hands free operation to provide additional safety

Several NitroLance jet configurations, angles, pressures and temperatures were used in this application, and resulted in complete clearing of tubes that had been fully blocked with deposit. The cleaning pressures ranged from 47,000 psi to 48,000 psi, and the per

tube duration of cleaning ranged from three to five minutes, depending on the severity of the obstructions. Bare metal was visible after cleaning which is the best result of all.



Figure 3. Exchanger prior to cleaning (left) and exchanger channel head removed, completely cleaned with NitroLance (right)

4. LN₂ COOLING EFFECTS ON BASE METAL

An evaluation of the effects of LN₂ on base metal was performed by Air Liquide Corporation to examine possible changes that liquid nitrogen might cause to the metal's grain boundaries and structure, as well as the potential for shrinkage or modifications of mechanical properties that might result from the cold temperatures. Micro-structural observation and micro-hardness measurements were performed on steel (ASTM A516 60) before and after LN₂ cleaning. As shown in Figure 4, LN₂ cleaning of basic carbon steel induced no micro-structural grain modifications or changes in the surface micro-hardness of the base metal.

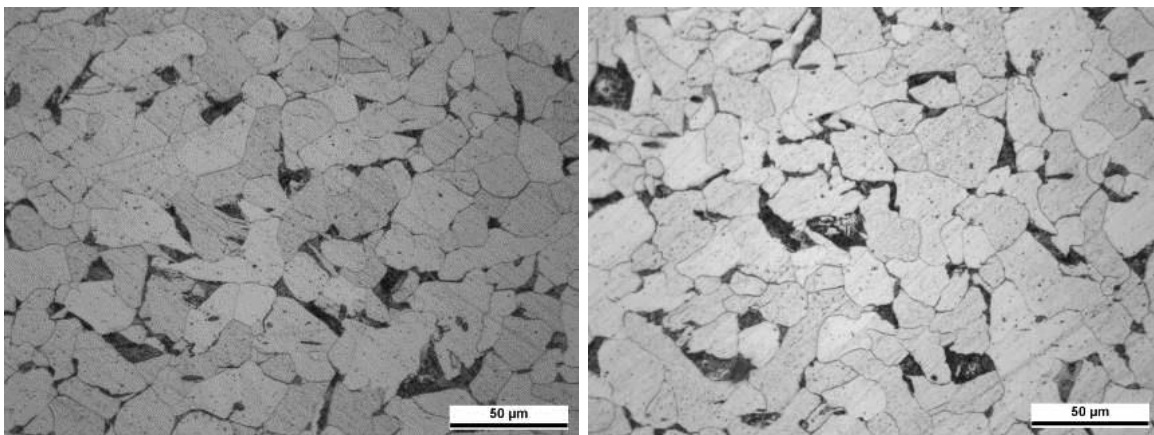

Figure 4. 3 μ m diamond polished ASTM A 516 60 before (left) and after (right) cleaning with liquid nitrogen.

Shrinkage or modifications to the base metal is avoided because the liquid nitrogen cleaning process is performed at a relatively fast rate of speed (greater than 10 ft./min). Combined with this fast speed and the metal's brief contact with the LN₂, the base metal only dropped in temperature between 9°F and 18°F on average. This small drop in

temperature induced no notable metal shrinkage and had no notable influence on the mechanical properties of the base metal.

5. CONCLUSION

There is strong anecdotal evidence and hard data to confirm the efficacy and safety of LN₂ cleaning in the petrochemical industry. Reports from and observations of industry applications strongly suggest that LN₂ is unique among other cleaning methods in its power to produce a positive effect for the equipment and the customer. In the end, plant personnel want cleaning to be conducted safely, fast and effectively. More and more plants are choosing to spend slightly more of the maintenance budget for a LN₂ cleaning because the return on investment is so significant compared to other cleaning methods. Cleaning components with LN₂ means fewer days of maintenance downtime, smaller crew sizes and drastically reduced post-cleaning disposal costs. Many plants operate with smaller maintenance budgets and with increased oversight and emphasis on regulatory compliance. This demands a smarter use of maintenance dollars on technology that yields great results without collateral expense. That said, working with LN₂ requires an apt and experienced hand, and petroleum plants must choose firms that have a strong resume of experience and success applying LN₂ on petroleum refinery process equipment.